

# Reducing Tee

**Connects 2 equal pipe/tube sizes and a reduced branch connection.**

## Overview

John Guest reducing tee push-fit fitting connects two equally sized pipes/tubes and a reduced branch feed. Fast and simple to install, John Guest Air and Pneumatics creates an instant connection and airtight seal without the need for tools, hot works or sealing agents. Air piping systems can be set up and installed 50% quicker than traditional methods.

The unique collet locking design firmly and securely holds the pipe in place without deforming the pipe or restricting flow. Fittings are also fully demountable, reducing system downtime during maintenance and making it quick and easy to modify or extend systems.

Designed in tough engineered plastic, fittings are compatible with John Guest nylon, powder coated aluminium or LLDPE tubing, as well as copper, PEXa and other soft metal pipe materials. All John Guest fittings are manufactured and assembled in the UK.



## Features & Benefits

- Strong acetal copolymer fitting with nitrile O-Ring
- Airtight connection with superior flow characteristics
- Instant push-fit connection and demountable without tools
- Secure collet cover prevents accidental disconnection
- Suitable for air and pneumatics piping systems up to 10 bar
- Ideal for air, inert gases and vacuum applications
- Food grade fitting suitable for potable liquids
- Compatible with soft metal or plastic pipe/tubing

Product code	Description	Size	Bag QTY
PI301208S	Reducing Tee	3/8" x 3/8" x 1/4"	10
PI301612S	Reducing Tee	1/2" x 1/2" x 3/8"	10



# Reducing Tee

## Working parameters & specifications

Application	Maximum working pressure, bar
Air	16 Bar

Materials	
Body	Plastic
O-Ring	Nitrile, Black
Collet	Acetal Copolymer (Unfilled)
Collet Teeth	Stainless Steel 301

## Dimensions – All measurements in mm unless otherwise stated

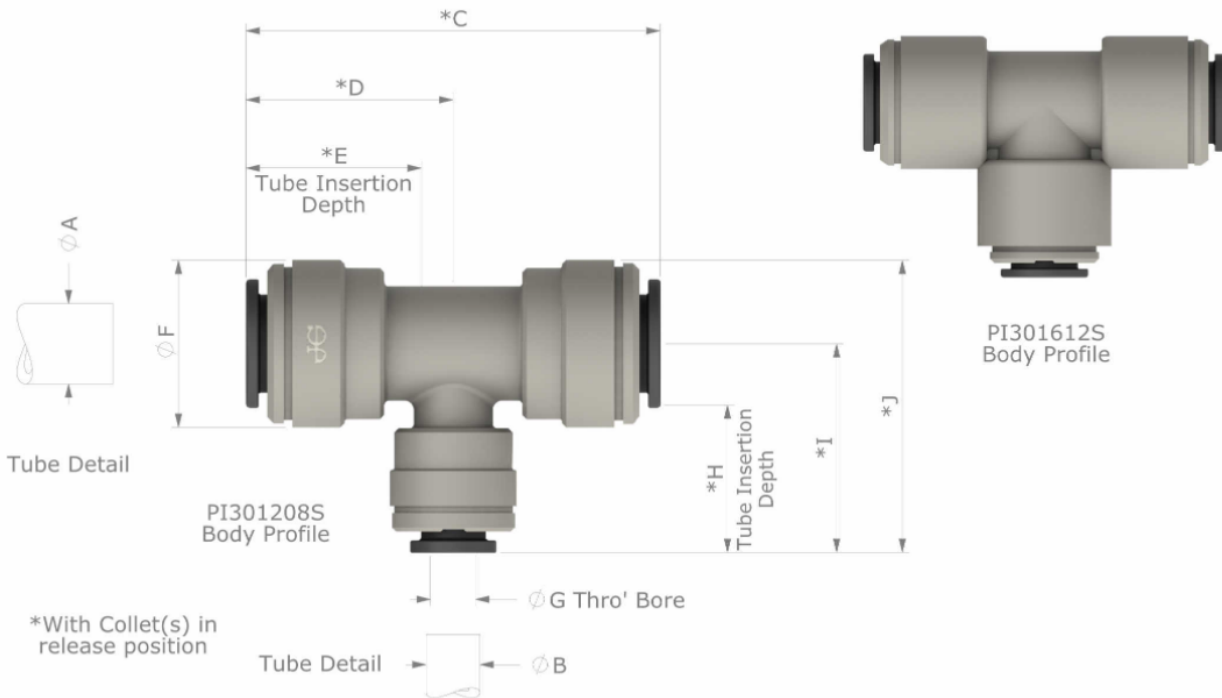

Product No.	Size	A Tube O/D	B Tube O/D	C	D	E	F	G	H	I	J
PI301208S	3/8" - 1/4"	0.375 +0.001 / -0.004 [9.53 +0.03 / -0.10]	0.250 +0.001 / -0.004 [6.35 +0.03 / -0.10]	1.85 [46.9]	0.92 [23.5]	0.78 [19.7]	0.78 [19.8]	0.21 [5.3]	0.62 [15.7]	0.90 [23.0]	1.29 [32.9]
PI301612S	1/2" - 3/8"	0.500 +0.001 / -0.004 [4.76 +0.03 / -0.10]	0.375 +0.001 / -0.004 [9.53 +0.03 / -0.10]	2.40 [61.0]	1.20 [30.5]	0.91 [23.0]	0.92 [23.3]	0.30 [7.5]	0.78 [19.7]	1.16 [29.5]	1.62 [41.1]

Dimensions in Inches & [mm]