

Swivel Elbow (Brass BSP Thread)

Connects metric to imperial sized pipe to form a swivel type 90 degree pipe bend

Overview

John Guest swivel elbow (BSP thread) push-fit fitting connects metric to a FBSP thread connection to form a 90° swivel type connection. Fast and simple to install, John Guest Air and Pneumatics creates an instant connection and airtight seal without the need for tools, hot works or sealing agents. Air piping systems can be set up and installed 50% quicker than traditional methods.

The unique collet locking design firmly and securely holds the pipe in place without deforming the pipe or restricting flow. Fittings are also fully demountable, reducing system downtime during maintenance and making it quick and easy to modify or extend systems.

Designed in tough engineered plastic, fittings are compatible with John Guest nylon, powder coated aluminium or LLDPE tubing, as well as copper, PEXa and other soft metal pipe materials. All John Guest fittings are manufactured and assembled in the UK.



Features & Benefits

- Strong acetal copolymer fitting with nitrile O-Ring
- Airtight connection with superior flow characteristics
- Instant push-fit connection and demountable without tools
- Secure collet cover prevents accidental disconnection
- Suitable for air and pneumatics piping systems up to 10 bar
- Ideal for air, inert gases and vacuum applications
- Food grade fitting suitable for potable liquids
- Compatible with soft metal or plastic pipe/tubing

Product code	Description	Size	Bag QTY
MM090611	Swivel Elbow (BSP Thread)	6mm x 1/8"	10
MM090612	Swivel Elbow (BSP Thread)	6mm x 1/4"	10
MM090812	Swivel Elbow (BSP Thread)	8mm x 1/4"	10



Swivel Elbow (BSP Thread)

Working parameters & specifications

Application	Maximum working pressure, bar
Air	16 Bar

Materials	
Body	Acetal Copolyme (Unfilled) and Brass
O-Ring	Nitrile, Black
Collet	Acetal Copolymer (Unfilled), Black
Collet Teeth	Stainless Steel 301

Dimensions – All measurements in mm unless otherwise stated

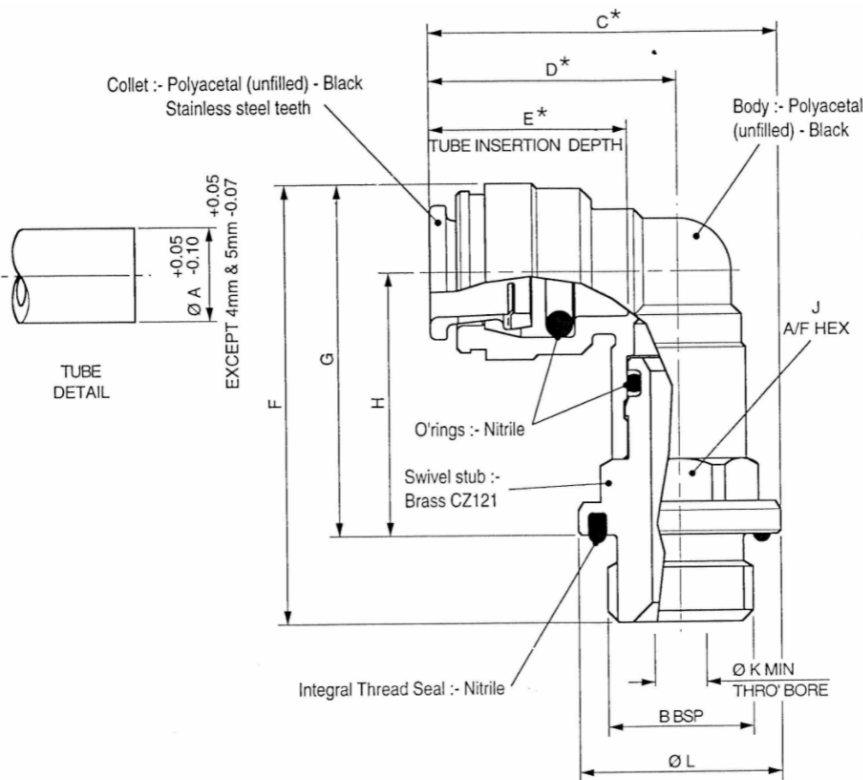

* These dims with collet in fully released position.

Product No.	Ø A	B BSP	Dim C*	Dim D*	Dim E*	Dim F	Dim G	Dim H	Dim J	Ø K	Ø L
MM090411	4	1/8	25.3	17.8	14.3	33.2	27.7	21.5	11	3.4	15.0
MM090611	6	1/8	27.0	19.5	15.8	34.4	28.8	21.8	11	3.8	15.0
MM090612	6	1/4	28.7	19.5	15.8	35.8	29.1	22.3	13	3.8	18.4
MM090812	8	1/4	30.6	21.4	16.9	39.9	32.2	24.2	13	5.2	18.4

All dimensions in mm