

Elbow (Superseal to Speedfit)

Quickly and securely connects plastic or soft metal pipe/tube to polished metal pipe/tube to form a 90° pipe bend

Overview

John Guest superseal push-fit elbow fitting connects two stainless steel or other polished metal pipe/tubes to form a 90° pipe bend. Fast and simple to install, John Guest push-fit fittings create an instant push-fit connection and leak tight seal without the need for tools, hot works or sealing agents.

The unique collet locking design firmly and securely holds the pipe in place without deforming the pipe or restricting flow. The superseal provides extra grip and the hand-operated nut and wedge plastic washer applies pressure on the collet and double nitrile O-Rings, ensuring the stainless-steel teeth bite firmly onto the pipe, while compressing the O-Rings to enhance the seal.

The fittings are manufactured from acetal, are corrosion resistant and fully demountable, improving system performance and reducing system downtime during maintenance. Manufactured in grey push-fit acetal copolymer, the fitting is suitable for potable liquids, foodstuff, inert gas and intermittent hot water applications. All John Guest fittings are manufactured and assembled in the UK.



Features & Benefits

- Nitrile food grade O-ring for potable liquids and foodstuff (not suitable for air, pneumatic or vacuum applications)
- Superseal feature provides extra grip on stainless steel and other hard polished metal pipe/tube
- Instant push-fit connection with hand-tighten nut for added compression
- Connect, disconnect and reconnect in seconds without tools
- No scale build up improves performance and equipment lifespan
- Superior flow characteristics

Product Code	Description	Size
SI030812S	Elbow	1/4" - 3/8"
SM030808S	Elbow	5/16" - 5/16"
SI031012S	Elbow	5/16" - 3/8"
SI031210S	Elbow	3/8" - 5/16"
SI031212S	Elbow	3/8" - 3/8"



Elbow (Superseal to Speedfit)

Application	Maximum working temperature °C	Maximum working pressure, bar
Potable Water	20	10
Intermittent Hot Water	60	4

Materials	
Body	Acetal Copolymer
O-Ring	Nitrile
Collet	Acetal Copolymer
Collet Teeth	Stainless Steel 301

Application
Potable Liquid
Food Grade Liquids
Not Suitable for Compressed Air & Vacuum

Dimensions – All measurements in mm unless otherwise stated

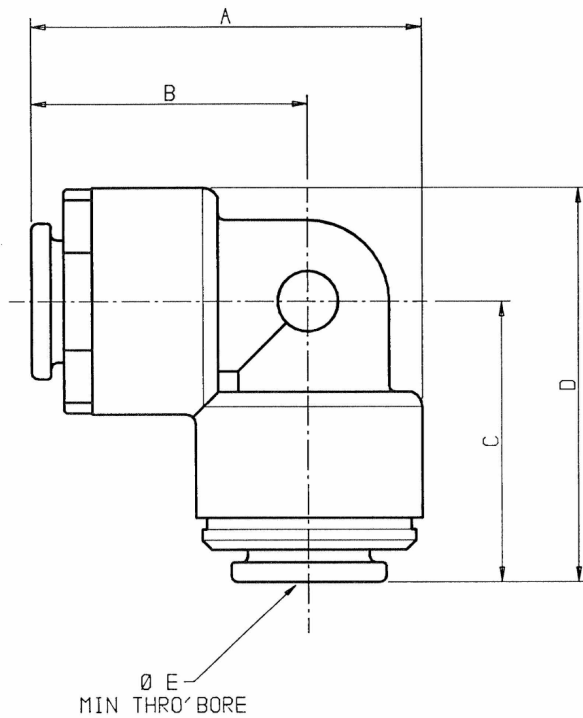

PRODUCT NO.	DESCRIPTION	A	B	C	D	Ø E
SM030808S	5/16 S.SEAL X 5/16 S.FIT	1.40	1.05	0.83	1.17	0.25
SI031012S	5/16 S.SEAL X 3/8 S.FIT	1.47	1.08	0.98	1.36	0.25
SI031210S	3/8 S.SEAL X 5/16 S.FIT	1.57	1.19	0.98	1.36	0.25
SI031212S	3/8 S.SEAL X 3/8 S.FIT	1.57	1.19	1.00	1.38	0.30

ALL DIM IN IMPERIAL