

Grey Acetal Reducing Bulkhead Connector Imperial

Connects imperial pipe connections that are made through walls or partitions

Overview

John Guest push-fit reducing bulkhead connector fitting for the connection of unequal sized pipe in through-wall applications. Fast and simple to install, John Guest push-fit fittings create an instant push-fit connection and leak tight seal without the need for tools, hot works or sealing agents.

The unique collet locking design firmly and securely holds the pipe in place without deforming the pipe or restricting flow. Fittings are corrosion resistant and fully demountable, improving system performance and reducing system downtime during maintenance.

Manufactured in grey push-fit acetal copolymer, the fitting is suitable for foodstuff, potable liquids and inert gases. In accordance with the British Beer & Pub Association Code of Practice, fittings can also be used with N₂/CO₂ and mixed gas dispense lines, as well as air, pneumatic and vacuum applications. All John Guest fittings are manufactured and assembled in the UK.



Features & Benefits

- Strong acetal copolymer fitting with nitrile O-Ring
- Airtight connection with superior flow characteristics
- Instant push-fit connection and demountable without tools
- Secure collet cover prevents accidental disconnection
- Suitable for air and pneumatics piping systems up to 10 bar
- Ideal for air, inert gases and vacuum applications
- Food grade fitting suitable for potable liquids
- Compatible with soft metal or plastic pipe/tubing

Product code	Description	Size
PII21208S	Reducing Bulkhead	3/8" - 1/4"
NC2429	Reducing Bulkhead	1/4" - 6mm



Grey Acetal Bulkhead Connector Imperial

Application	Maximum working pressure, bar
Air	16 Bar

Materials	
Body	Acetal Copolymer (Unfilled)
O-Ring	Nitrile, Black
Collet	Acetal Copolymer (Unfilled)
Collet Teeth	Stainless Steel 301

Application
Potable Liquid
Food Grade Liquid
Inert Gases
Vacuum

Dimensions – All measurements in mm unless otherwise stated

*With Collet(s) in release position

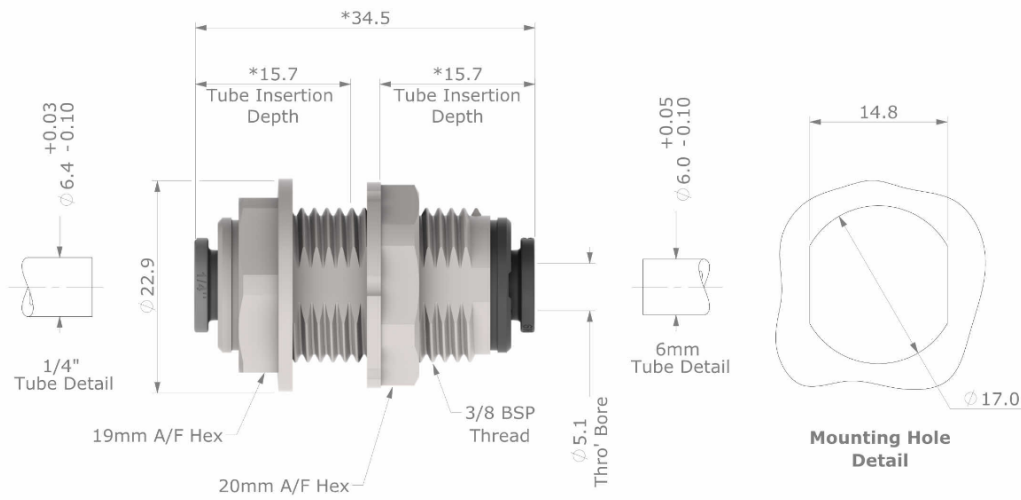

Dimensions in mm